

Sample Diploma Problem

Use the following information to answer question 8.

A Venn Diagram Representing Different Types of Current

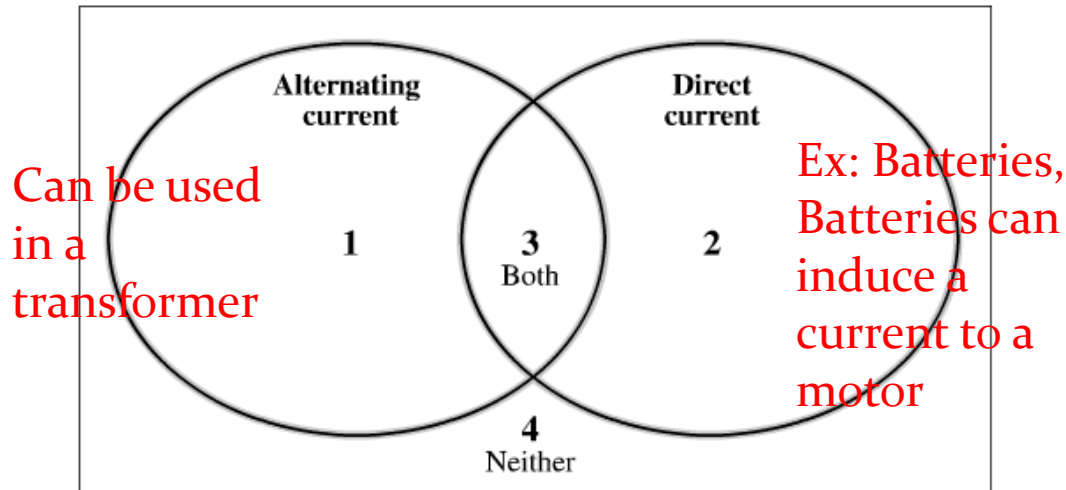

8. Which of the following rows contains a statement that should be placed in Area 1 and a statement that should be placed in Area 3 of the Venn diagram above?

Row	Area 1	Area 3
A.	Output of a battery	Input for a transformer
B.	Output of a battery	Input for a motor
C.	Output of a transformer	Input for a transformer
D.	Output of a transformer	Input for a motor

Sample Diploma Problem

Use the following information to answer question 10.

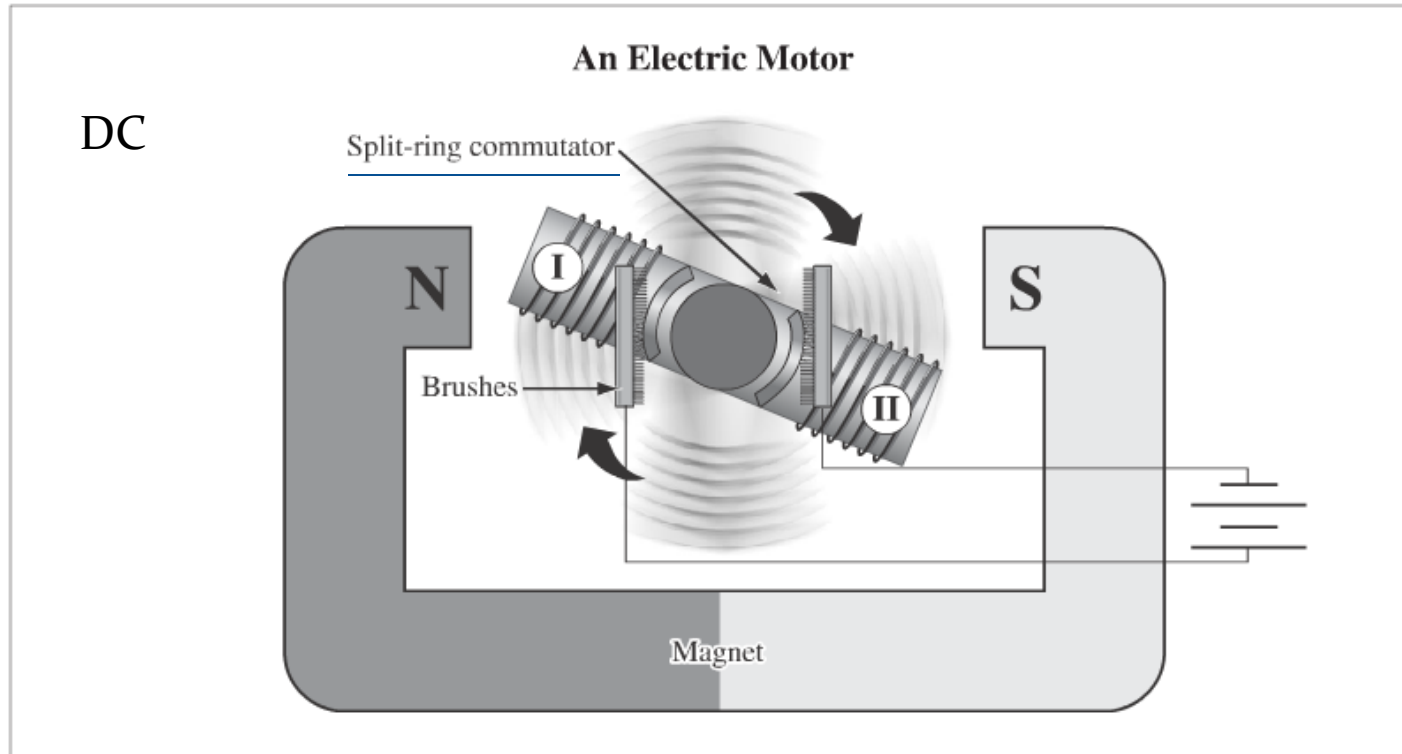

10. The purpose of the electric motor shown above is to convert electrical energy to

- A. kinetic energy
- B. potential energy
- C. electrical energy
- D. magnetic energy

Motors turn electricity into motion (kinetic energy)

Use the following information to answer question 11.

The generator shown below is similar to one that would be found in a coal-fired generating plant.

AC

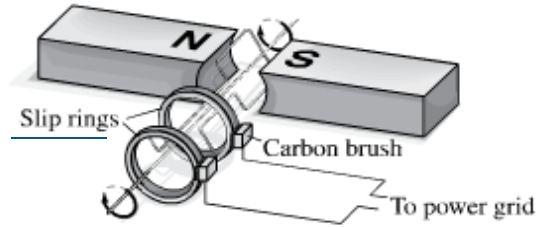

11. Which of the following rows describes the type of current produced by the generator above and shows the graph of the resulting voltage?

Row	Current	Graph
A.	AC	<p>The graph shows a vertical axis with '+ Volts' at the top, '0' in the middle, and '- Volts' at the bottom. The horizontal axis is labeled 'Time (s)'. A dashed sine wave starts at the origin (0,0), goes up to a peak, crosses the zero line, goes down to a trough, and crosses the zero line again.</p>
B.	AC	<p>The graph shows a vertical axis with '+ Volts' at the top, '0' in the middle, and '- Volts' at the bottom. The horizontal axis is labeled 'Time (s)'. A dashed horizontal line is drawn at a constant positive voltage level above the zero line.</p>
C.	DC	<p>The graph shows a vertical axis with '+ Volts' at the top, '0' in the middle, and '- Volts' at the bottom. The horizontal axis is labeled 'Time (s)'. A dashed sine wave starts at the origin (0,0), goes up to a peak, crosses the zero line, goes down to a trough, and crosses the zero line again.</p>
D.	DC	<p>The graph shows a vertical axis with '+ Volts' at the top, '0' in the middle, and '- Volts' at the bottom. The horizontal axis is labeled 'Time (s)'. A dashed horizontal line is drawn at a constant positive voltage level above the zero line.</p>

DC need split rings

Circuits

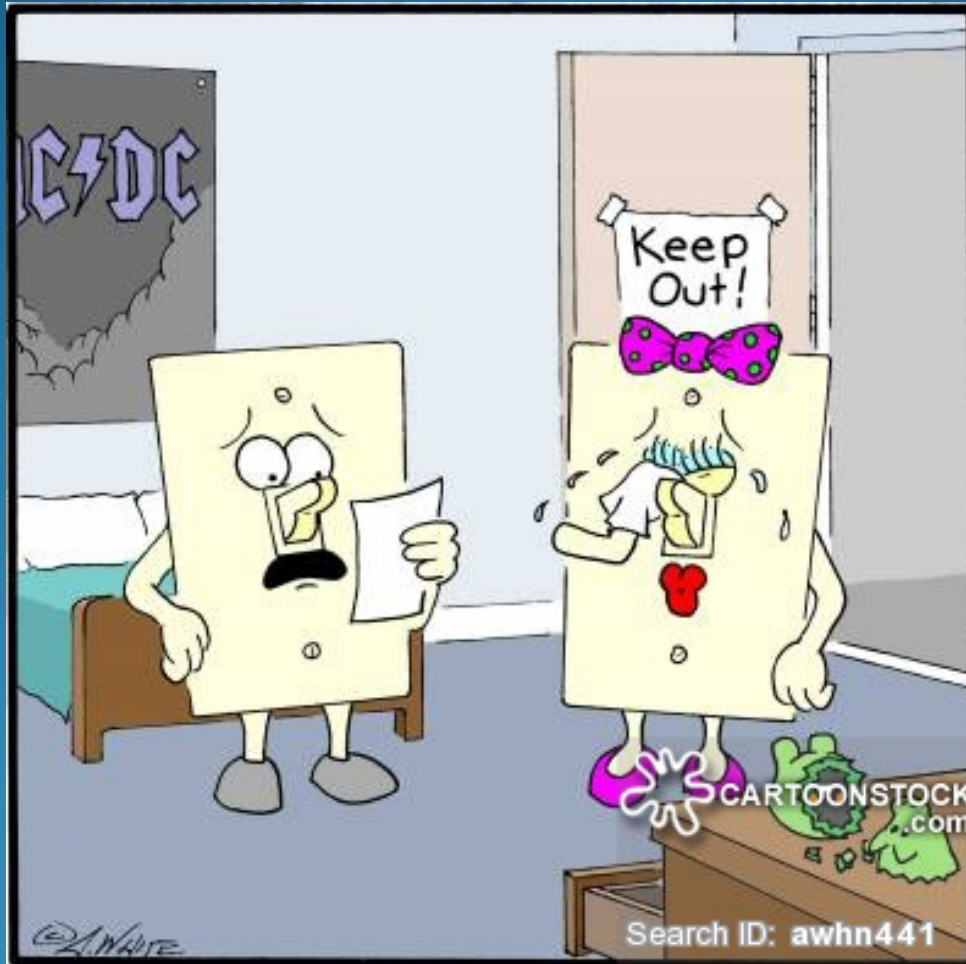

“Dear Mom and Dad, I’m running away from home to join the circuits.”

Curriculum

- describe the relationships, for up to three resistors, among power, current, voltage and resistance for series and parallel circuits, using the equations $V = IR$, $P = VI$, $P = I^2R$, $R_T = R_1 + R_2 + R_3$, and $\frac{1}{R_T} = \frac{1}{R_1} + \frac{1}{R_2} + \frac{1}{R_3}$
- calculate the resistance of series and parallel circuits for a maximum of three resistors
- calculate values for power, current, voltage and resistance
- describe, in terms of design and electrical energy, the functioning of safety technologies

Electric Circuits

- Circuits are used to transport electricity to an object.
- You can measure Current (I) using an ammeter; Voltage (V) using a voltmeter.
- There are 2 types of circuits:
 - Series- only one path for electricity to flow.
 - Parallel- more than 1 path for electricity to flow.

Series Circuits

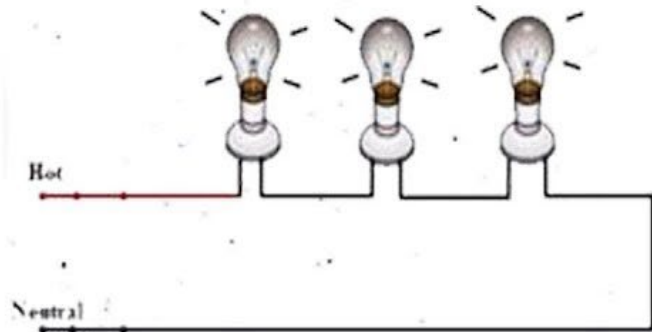

VS

Parallel Circuits

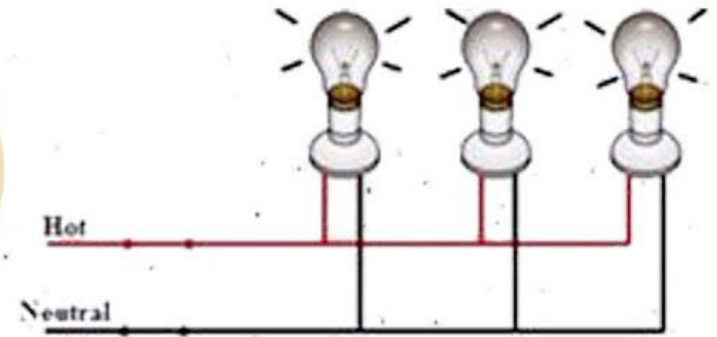

Difference Between Series and Parallel circuit

Parallel and Series Circuits

- Circuits can be divided into two general types: **parallel and series**
- These circuit types are defined by the number of branches that are present in the circuit

SERIES

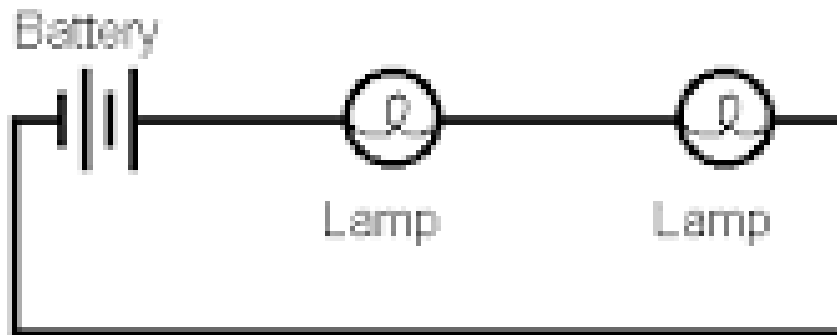

Series Circuits

- **Series circuits** are when current passes through each bulb in turn
- There is only one pathway for the current
- When you add bulbs to this circuit, it increases resistance, making all the bulbs dimmer
- A light switch in a house would be wired in series so it can turn off all the lights

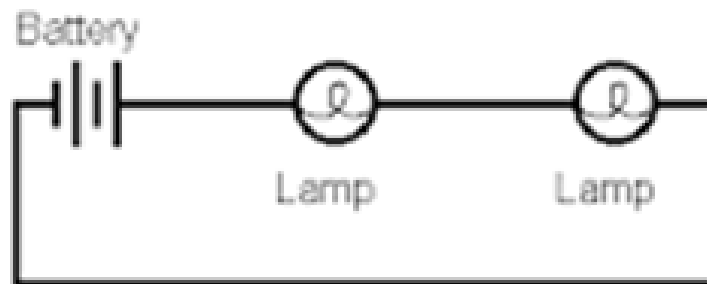

Parallel Circuits



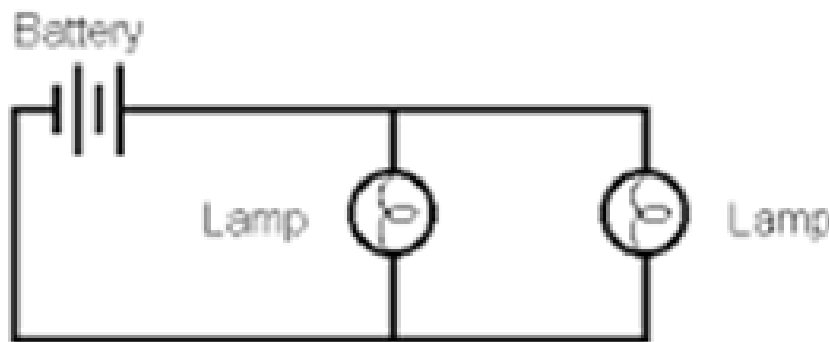





- **Parallel Circuits** have a separate path for each section of the circuit.
- If you interrupt a circuit, this would not affect the other circuits
- Adding extra circuits actually lowers resistance of the overall circuit

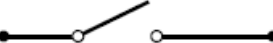
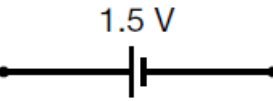
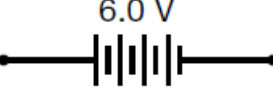

Analyzing and Building Circuits

- Circuit diagrams or schematics are representations of a circuit that is built
- All circuits require four components:
 - A source that provides the energy
 - A conductor that provides a path for current (wire)
 - A switching mechanism that can turn power on or off
 - A load that converts electrical energy into some other form (light bulb, motor)

Common Symbols

Component	Circuit Symbol	Function
wire		passes current from one part of a circuit to another
wires joined		connects wires or components
switch		allows current to flow only when the switch is in the closed position
cell or DC power supply		supplies electrical energy to a circuit in the form of direct current (DC) Note: The longer terminal is positive.
battery		supplies electrical energy to a circuit in the form of direct current (DC)
resistor		resists the flow of electric current
lamp		converts electrical energy into light energy
voltmeter		measures voltage
ammeter		measures electric current
ohmmeter		measures resistance

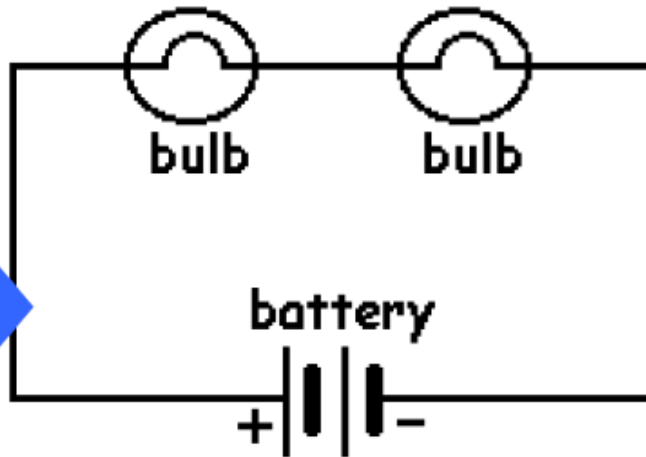
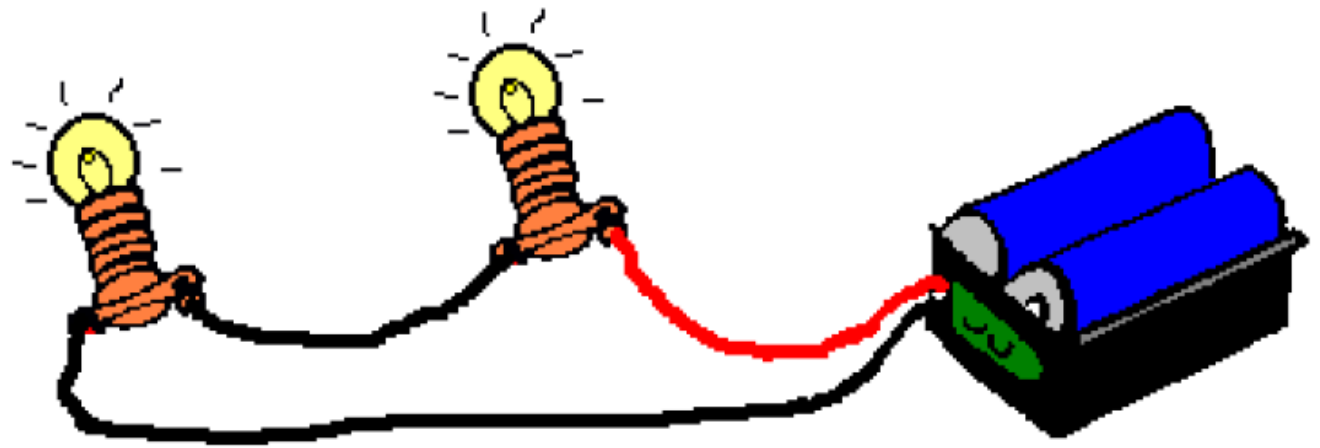

Circuit Diagram

Series Circuit

Example

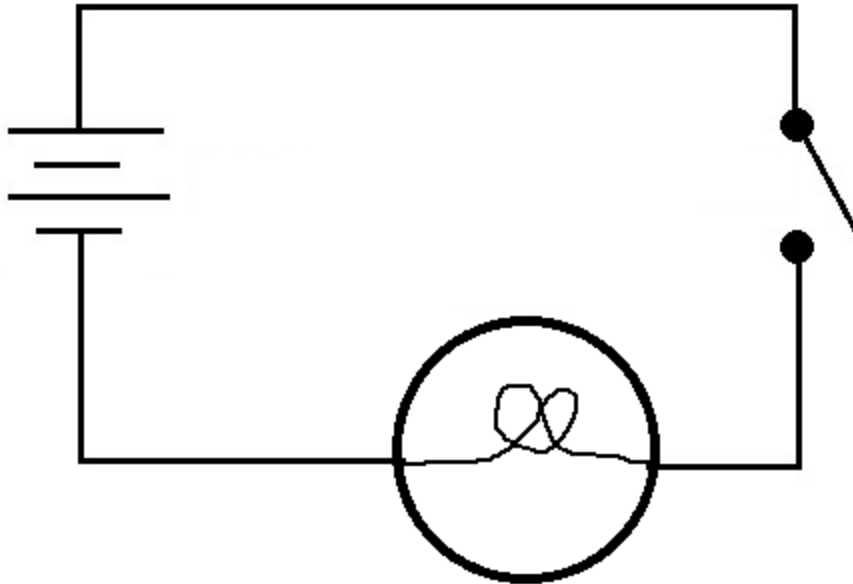

Applications of Parallel and Series Circuits

- Parallel circuits are more commonly used in devices than series circuits
- Imagine what would occur if your house used series circuits instead of a number of parallel circuits...



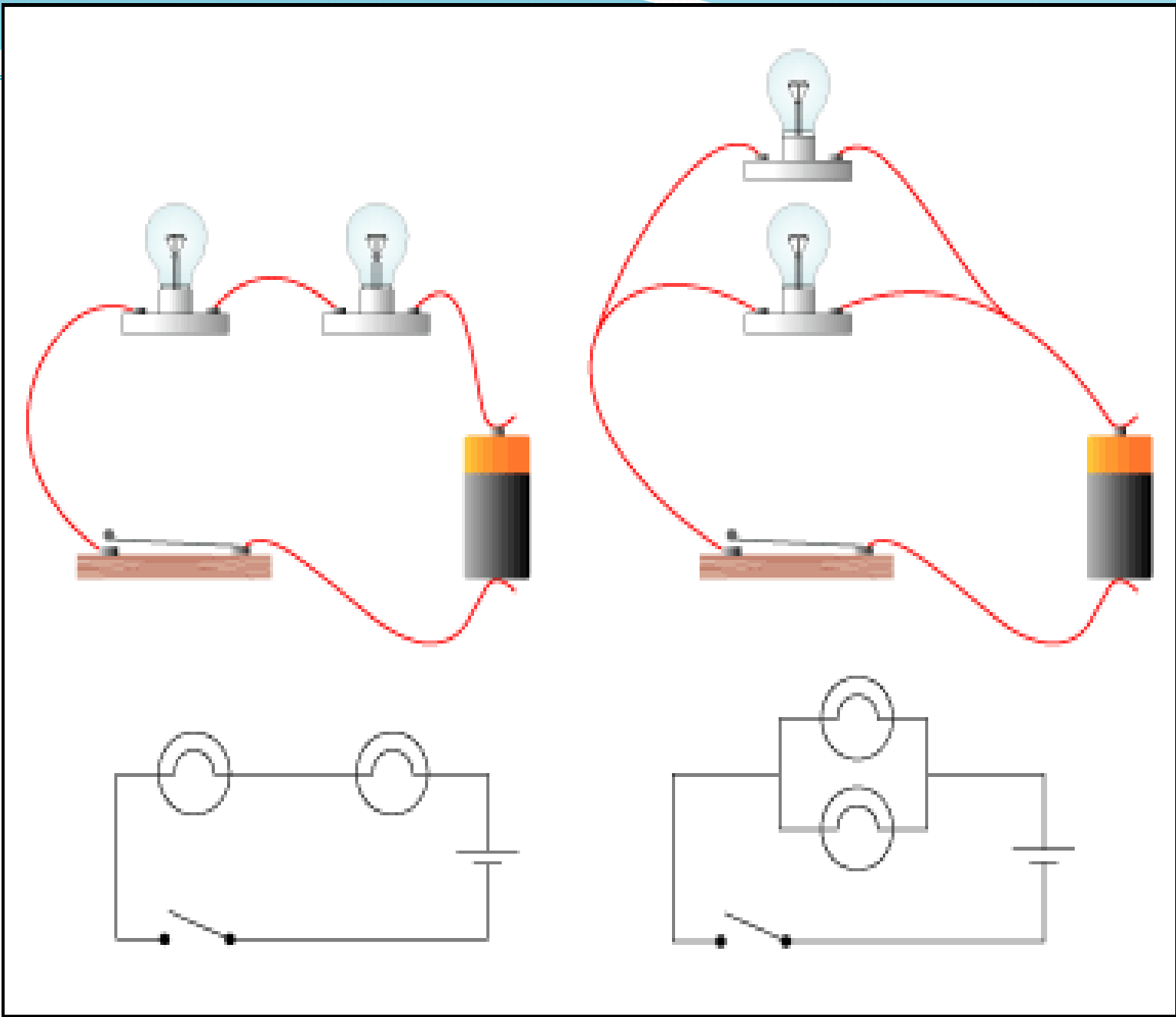

Using Test Meters

- **Voltmeters** measure voltage and must be connected on either side of a device (in parallel)
- **Ammeters** measure current and should show the same reading on any point of the circuit (in series)
- **Galvanometers** measure small currents
- **Multimeters** can measure voltage, current, or resistance

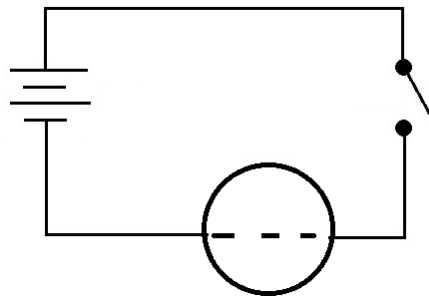

Meters

A voltmeter measures the potential difference between two points in a circuit so it must be connected in parallel

- Ammeters measure current at a single point and must be connected in series. (Connecting an ammeter in parallel may cause damage to the device)

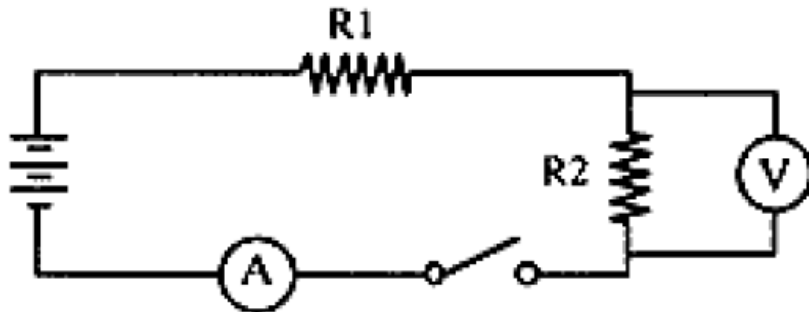

Example

- Show how you would hook up a voltage meter and an ammeter to a circuit with 2 bulbs in series and a battery.

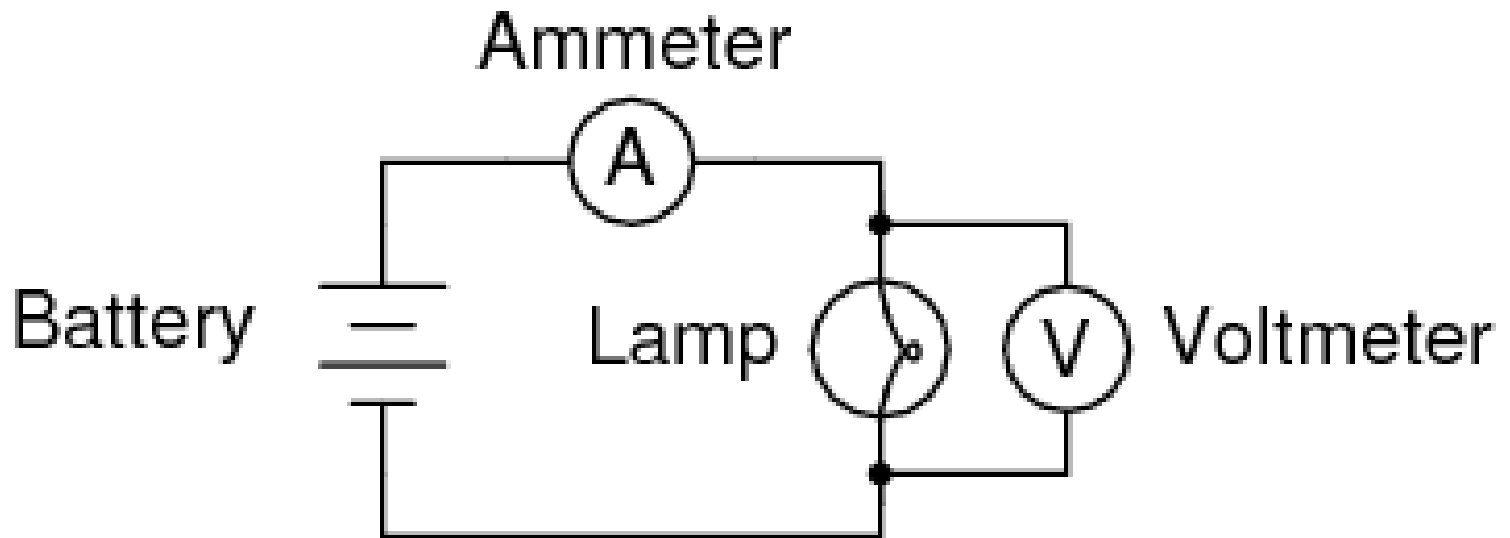

Protecting From Shock

- If a **fuse or breaker** receives too much current, the circuit is broken and the current stops
- Fuses must be replaced after they burn out, but breakers can be reset

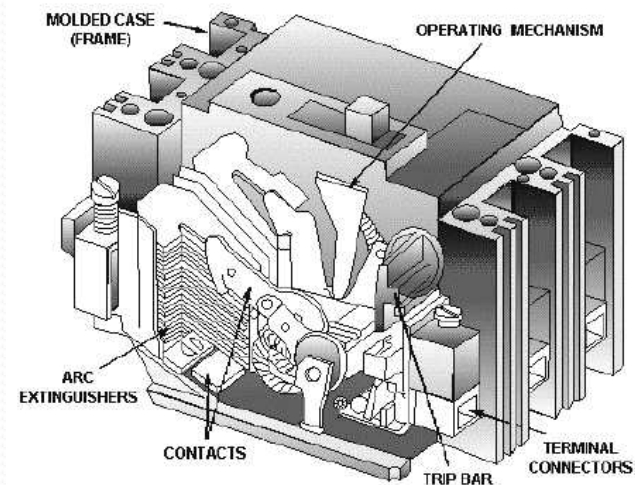
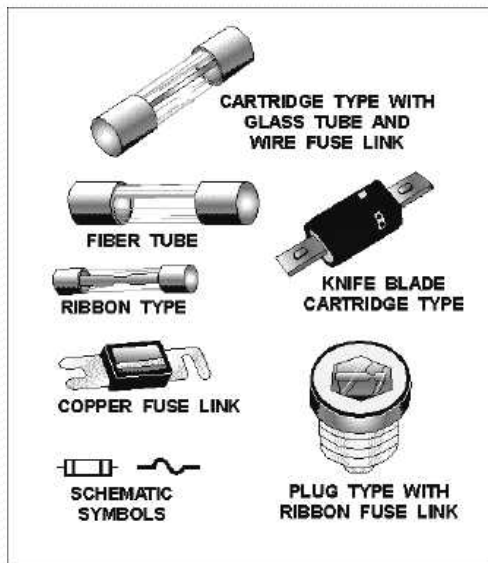

Using Conductors, Resistors & Insulators

- Resistors are parts of a circuit that provide high resistance to reduce the amount of current flowing through the circuit
- **Resistance** is a measure of how difficult it is for electrons to flow
- Resistance is measured in **ohms (Ω)**

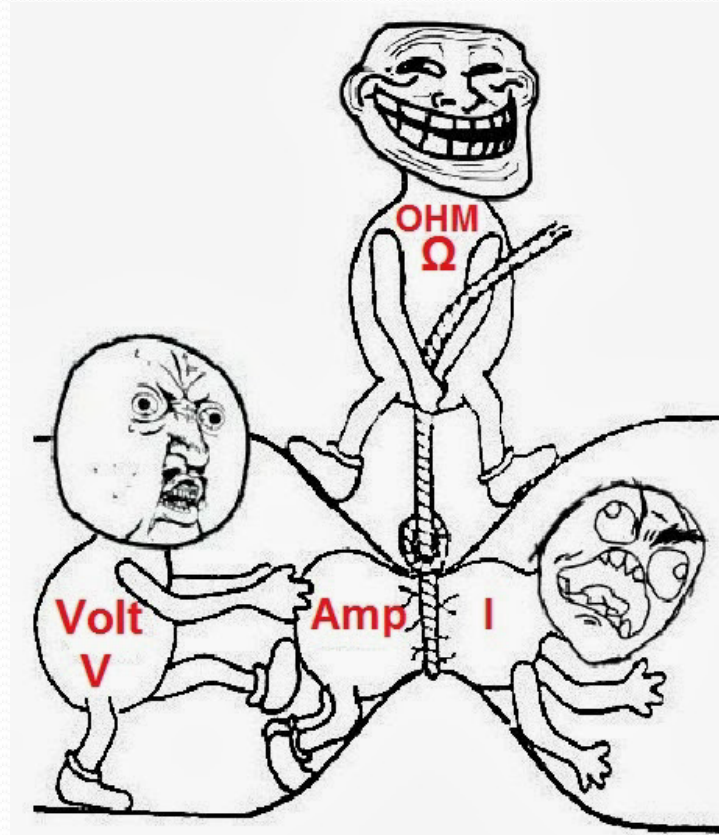

Switches and Variable Resistors

- **Switches** create a break in the circuit that interrupts current flow, therefore controlling the flow of current in the circuit
- A **variable resistor** is another type of control
- These resistors (also known as rheostats) allow you to adjust the amount of current flowing through a circuit, rather than simply turning it on or off



Factors that Affect Resistance

- Resistance within a conductor depends on temperature
- Resistance increases as temperature increases
- For a resistor to work best, it must be kept cool
- The thicker and shorter the wire, the less resistance



Modeling and Measuring Electricity

- **Voltage** is a measure of how much potential energy each electron that flows through a circuit possesses
- Voltage is related to both current and resistance in circuits
- Voltage can be found using Ohm's Law:

Ohm's Law

$$V = I * R$$

voltage in volts current in amps resistance in ohms

- The slope of a voltage-current graph is the resistance

$$R = \frac{V}{I} = \frac{\textit{rise}}{\textit{run}}$$

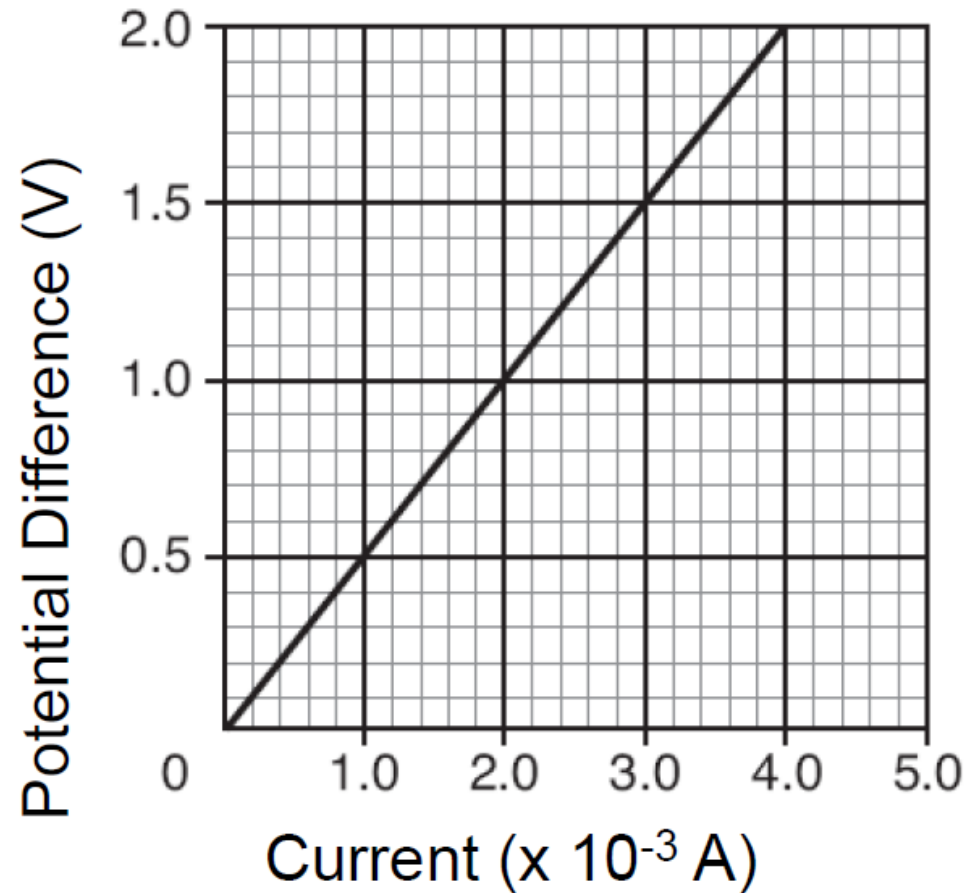

$$R = \frac{V}{I}$$

Example

- A stove is connected to a 240 V outlet. If the current flowing through the stove is 20 A, what is the resistance of the heating element?
- $V = 240$ voltage $I = 20$ A $R = ?$ $V = IR$

$$\frac{240V}{20A} = 12\Omega$$

the resistance of the heating element is 12Ω (ohm)

$$I = \frac{V}{R}$$

Example

- A 12 V battery runs through a 15 Ω resistor. What current is produced?

$$V = 12V \quad R = 15\Omega \quad I = ?$$

$$\frac{12V}{15\Omega} = 0.8A$$

Total Resistance in Series

- For resistors in series, there is only **one path** for electricity to flow
- the current has to overcome the resistance of every bulb as it goes through the circuit
- For a circuit in series

For resistances connected in series

$$R_T = R_1 + R_2 + R_3 + \dots R_n$$



(a) Resistors connected in series

Total Resistance in Parallel

- In a parallel circuit there are **multiple paths** for electricity to flow
- The more resistors in parallel we add on, the more paths electricity can move
- This makes the current flow more easily and reduces that resistance
- For circuits in parallel:

For resistances connected in parallel

$$\frac{1}{R_T} = \frac{1}{R_1} + \frac{1}{R_2} + \frac{1}{R_3} + \dots + \frac{1}{R_n}$$

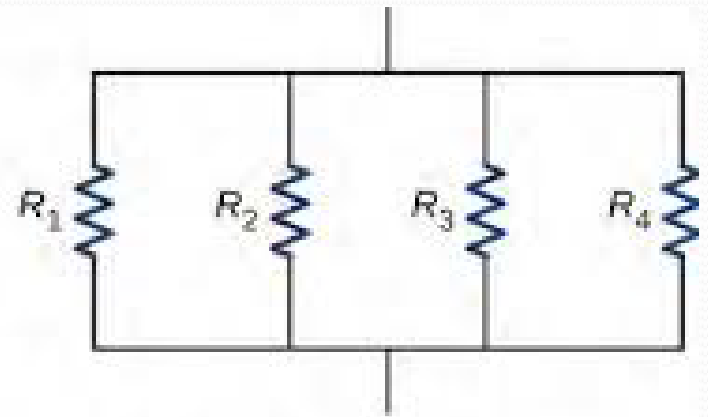

(b) Resistors connected in parallel

Example

- A set of Christmas lights is wired in series. A string has 8 bulbs, each with a resistance of 64.0Ω .
 - Draw a schematic diagram of this

A set of Christmas lights is wired in series. A string has 8 bulbs, each with a resistance of 64.0Ω .

- Find the resistance across the entire string
- $R_t = R_1 + R_2 \dots R_8 \quad (64\Omega)8 \rightarrow 512\Omega$
- If the lights are plugged into a 120 V outlet, calculate the current that will flow through it
- $V = IR \rightarrow I = V/R$

$$\frac{120V}{512\Omega} = 0.234A$$

Example

- During a dance students set up 5 spotlights wired in parallel. Each light has a resistance of $96\ \Omega$. They are hooked up to a $240\ \text{V}$ outlet.
 - Why is it a good idea for the lights to be in parallel?
 - If it were in a series if one spotlight went out, they all would. Where as, in a parallel, each spotlight can be turned off independently.
 - Draw a schematic diagram

During a dance students set up 5 spotlights wired in parallel. Each light has a resistance of 96Ω . They are hooked up to a 240 V outlet.

For resistances connected in parallel

$$\frac{1}{R_T} = \frac{1}{R_1} + \frac{1}{R_2} + \frac{1}{R_3} + \dots + \frac{1}{R_n}$$

- Find the total resistance

$$\frac{1}{R_T} = \frac{1}{96\Omega} \times 5 \rightarrow \frac{1}{0.0520833} = 19.2\Omega$$

$5 (1/96) = \text{ans}^{-1}$ also gives correct answer

$$I = \frac{V}{R}$$

- What is the current required to power all 5 lights?

$$\frac{240V}{19.2\Omega} = 12.5 A$$

Board Question

- Two $20\ \Omega$ light bulbs are set up in series connected two $6.0\ \text{V}$ batteries
- Draw a schematic diagram

For resistances connected in series

$$R_T = R_1 + R_2 + R_3 + \dots R_n$$

- Calculate the total resistance of the two bulbs
- $2(20\ \Omega) = 40\ \Omega$

Two $20\ \Omega$ light bulbs are set up in series
connected two $6.0\ \text{V}$ batteries

$$I = \frac{V}{R}$$

- Determine the current available to the bulbs

$$(6.0 + 6.0)$$

$$\text{-----} = 0.3\text{A}$$

$$40\ \Omega$$

- Explain what happens if one of the bulbs burns out
- Because its in a series they both will go out

Board Question

- Two $20\ \Omega$ light bulbs are set up in parallel connected two $6.0\ \text{V}$ batteries
- Draw a schematic diagram

For resistances connected in parallel

$$\frac{1}{R_T} = \frac{1}{R_1} + \frac{1}{R_2} + \frac{1}{R_3} + \dots + \frac{1}{R_n}$$

- Calculate the total resistance of the two bulbs

$$\frac{1}{R_T} = \frac{1}{20} \times 2 \rightarrow \frac{1}{0.1} = 10\ \Omega$$

Two $20\ \Omega$ light bulbs are set up in parallel connected two $6.0\ \text{V}$ batteries

$$I = \frac{V}{R}$$

- Determine the current available to the bulbs

$$12.0\text{V}/10 = 1.2\ \text{A}$$

- Explain what happens if one of the bulbs burns out
 - The other one will still stay on